

THERMOMAX

COLTREC RCX 100

MICROPROCESSOR REFRIGERATION
CONTROL SYSTEM

ENGLISH

www.Thermomax-Group.com

CONTENTS

SECTION 1 - INTRODUCTION	2
SECTION 2 - INSTALLATION	3
2.1 - RCX 100 UNIT	4
2.2 - SENSORS	4
2.3 - ALARM RELAY	5
2.4 - POWER CONNECTIONS AND WIRING DIAGRAM	5
SECTION 3 -RCX 100 OPERATION	6
3.1 - DESCRIPTION	6
3.1.1 - Display Select	6
3.1.2 - Status Indicators	7
3.1.3- Defrost & Alarm Set	7
3.2 - PROGRAMMING THE RCX 100:	
3.2.1- Displaying the Room temperature	8
3.2.2- Displaying the Evaporator temperature	8
3.2.3- Setting the Room temperature	8
3.2.4- Setting the Defrost Termination temperature	8
3.2.5- Setting the Fan Enable temperature	8
3.2.6- Setting the Alarm Low temperature	8
3.2.7- Setting the Alarm High temperature	8
3.2.8- Setting the Defrost Duration	8
3.2.9- Setting the Dwell period	9
3.2.10-Setting the Compressor Switch Delay	9
3.2.11-Setting the Alarm Delay period	9
3.2.12-Setting the Alarm Options	9
3.2.13-Setting the Defrost Frequency	9
3.2.14-Setting the Differential (Hysteresis)	10
3.3 - ADDITIONAL FEATURES:	10
3.3.1- Maximum and Minimum Record Temperatures	10
3.3.2- Keypad Lock	10
3.3.3- Manual Defrost	11
3.3.4- Sensor Calibration Trimming	11
3.3.5- Alarm Mute	11
3.3.6- Alarm Reset	11
3.3.7- Sensor Fault	11
SECTION 4 - FAULT FINDING	12
SECTION 5 - SPECIFICATIONS	13
SECTION 6 - NEW FEATURES OF RCX 100 PANELMOUNT	14
SECTION 7 - RCX 100 MINI-PANEL AND EASYFIX WIRING DIAGRAMS	16

SECTION 1 - INTRODUCTION

The COLTREC RCX 100 microprocessor-based system uses modern technology to ensure that the cold-room is controlled and monitored with the greatest of ease.

The RCX 100 may be connected directly to single-phase loads of up to 13A, and may be used in conjunction with contactors in larger or three phase installations.

SUMMARY OF FEATURES

CONTROLLER

- Digital display of room temperature.
- Digital display of evaporator
- Cold-room thermostat adjustable in 1°C steps with adjustable differential.
- Compressor switching limiter for short-cycling prevention.
- Fan enable thermostat.
- Fully programmable defrost with adjustable duration, termination temperature and dwell period.
- Manual defrost activation and override.

ALARM

- 2-Stage high and low level alarms with mute and reset facilities.
- Stage 1 temperature threshold with trigger delay.
- Stage 2 limit temperature with immediate trigger.
- Status window for system fault indication.

Note: The information supplied in this manual is for guidance Only - no part of this may be used for any agreement, whether expressed or implied, or to form any contract. Thermomax reserves the right to change specifications without prior notice.

SECTION 2 - INSTALLATION

NOTE: This installation procedure is for guidance only, and its suitability should be verified by the installer.

It is assumed that the refrigeration plant is physically installed and tested, and is ready for operation and connection to the electric supply.

SAFETY PRECAUTIONS

The following safety precautions are strongly recommended:

1. Before attempting to install and operate the unit read this instruction manual carefully.
2. Installation and any maintenance required should only be carried out by suitably qualified personnel.
3. It is recommended that the unit be connected to the mains supply via a suitably rated isolating switch.
4. **WARNING** : When the unit is connected to the mains supply and the cover is opened, circuits at mains voltage will be exposed. Therefore when installing the unit ensure all required connections (including battery connection, if included), are made and covers replaced before turning on the mains supply. Ensure that all the connections made are secure. If any maintenance work e.g. installing a new battery, is required ensure that the unit is isolated from the mains supply before removing the cover. Never leave the unit unattended if the cover has been removed and the mains supply is connected.
5. Do not exceed unit ratings as shown on the ratings label.
6. It is advisable to route mains cables away from low voltage or sensor cables.

Note: As each installation is different, the RCX 100 does not provide internal fusing for the Compressor, Fan or heater outputs. Therefore an appropriately rated external fuse (circuit breaker) should be fitted by the installer in series with the Live supply to the unit.

2.1 RCX 100 UNIT

NOTE: For viewing comfort, the RCX 100 should be positioned at eye level. It is always good practice to keep electronic controls away from extremes of cold, heat and electrical plant, as extremes of temperature may reduce the lifetime of the device, and heavy electrical loads, switches, relays or contactors too close to the device may cause electrical and electro-magnetic interference when switched on or off.

- 1- Knock out the entries into the moulding, either behind or under the box, whichever is suitable for your particular installation.
- 2- Fasten the screw corresponding to the top centre lug on the back of the RCX 100 unit, into the wall or panel on which the control box is to be mounted. Leave a gap of approximately 3mm between the screw head and the wall. Position the unit and slot in the lug over the screw.
- 3- Level the RCX 100 unit and, if using rear entry, mark the entry holes in the panel behind the appropriate knock-out entries, as well as the two lower mounting holes. Remove the unit, drill the necessary holes in the panel, assemble any grommets or conduit adapters if used, replace the box and fasten using the two lower screws.

2.2 SENSORS

Included are two identical temperature sensors, each supplied with 5m of cable. If required, sensors are available with extended cable lengths or alternatively, sensor extenders are available, also in a variety of lengths. If the sensors need to be extended but factory-made extenders are not available, they can be extended using a suitable 4 core or 3 core cable, according to the diagram shown below.



As with all PT100 sensor applications, a good connection is vital. It is therefore recommended that wherever there is any doubt, a factory-extended sensor or a sensor extender should be used.

- 1 Install the ROOM sensor in the cold-room, ensuring that it is not too close to either the evaporator fan or the door. Position the sensor such that it reads the average cold-room temperature.
- 2 Attach the EVAP sensor to the evaporator fins, ensuring that it is not too close to the defrost heater elements. Ideally, the sensor should measure the temperature of the evaporator coil, and should not be directly affected by the heater element. Therefore it is important to ensure good heat conduction between the evaporator tube and the sensor.
- 3 Complete the installation by routing the sensor cables back to the control box, ensuring that the cables are protected from sharp edges by suitable grommets or sleeves.

2.3 ALARM RELAY

NOTE: The alarm relay is a 3 contact changeover arrangement which is isolated (volt-free). This relay is normally energised, and switches off when the alarm is triggered, or in case of mains failure. It may be used to trigger an external bell, warning lamp, or digital communicator (telephone dialler). If an external device is used, connect the alarm relay as appropriate.

2.4 POWER CONNECTIONS AND WIRING DIAGRAM

NOTE: This device should be properly earthed. Flexible wires simplify connection to the terminals. All connections should be secure and adequately tightened, though not over-tightened, as loose power connections will over-heat, and may cause fire. It is important that the specified loads of 13A per output are not exceeded. Where these loads may be exceeded, external contactors should be used. It is good practice to keep mains cables away from sensor cables and other low voltage signal cables.

1. Connect the compressor, fan and defrost heater cables to the corresponding terminals in the RCX 100 unit, referring to the diagram below.
 2. Connect the mains wires.
- The unit is now ready to be powered up.

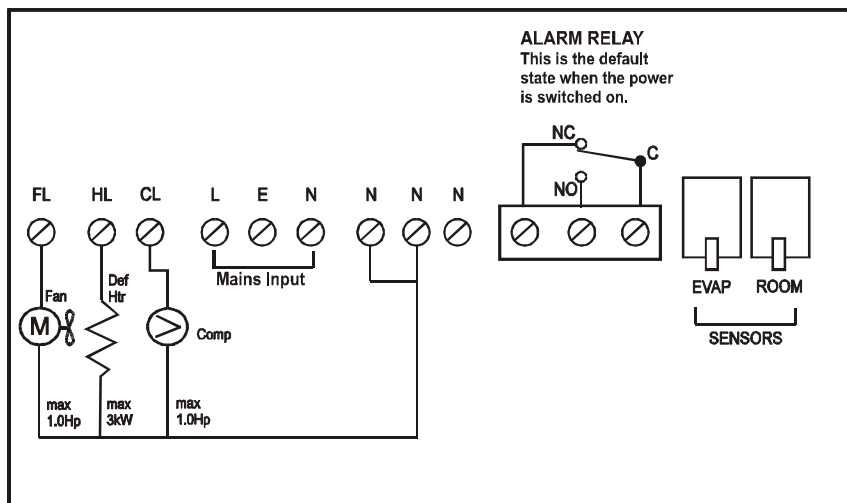

NOTE: If the outputs from the Compressor Live, Heater Live or Fan Live are connected to contactors, then the coil of the contactor should be properly suppressed from arcing by use of RC Suppressor modules.

SECTION 3 - RCX 100 OPERATION

In order to understand the operation of the RCX 100 this section should be read carefully.

3.1 DESCRIPTION

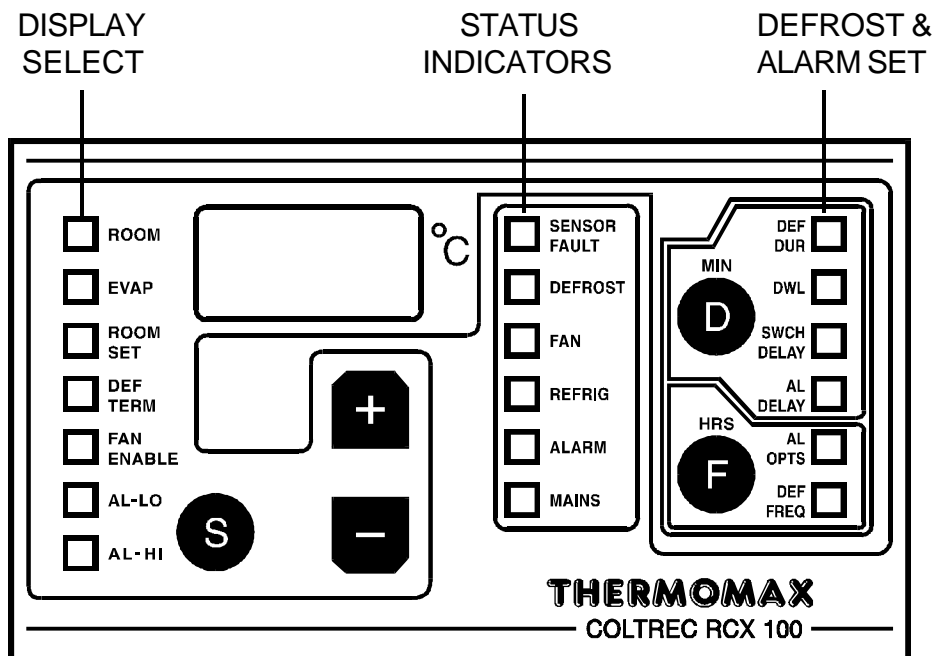

3.1.1 Display Select:

- ROOM:** Coldroom temperature
- EVAP:** Evaporator temperature
- ROOM SET:** Required cold room temperature (thermostat set point)
- DEF TERM:** Defrost Termination - maximum temperature limit for evaporator. If this value is exceeded during a defrost cycle, the defrost cycle automatically terminates irrespective of the state of the duration timer, and reverts back to the refrigeration cycle. At the end of the defrost cycle, the unit will 'dwell' for a period which can be programmed for "drain off" (See DWL overleaf).
- FAN ENABLE:** Fan activation thermostat set point. In operation after a defrost cycle, the fan is disabled until the evaporator temperature falls below this set point. It's main use is to prevent the heat generated by the defrost heaters being transferred into the cold room at the start of a refrigeration cycle.
- AL-LO:** Minimum temperature limit for the cold room. In operation, if this limit is exceeded, the alarm is triggered after a delay which is programmable from 0 to 50 minutes - see Alarm Delay and Alarm Options overleaf.
- AL-HI:** Maximum temperature limit for the cold room. In operation, if this limit is exceeded, the alarm is triggered after a delay which is programmable from 0 to 50 minutes - see Alarm Delay and Alarm Options overleaf.

3.1.2 Status Indicators:

- SENSOR:** This indicator flashes if there is a fault with any of the sensors.
- DEFROST:** Indicates that the defrost heater is on.
- FAN:** Indicates that the fan is on.
- REFRIG:** Indicates that the refrigeration compressor is on.
- ALARM:** This indicator flashes if one of the alarms has been triggered - as a result of the LOW alarm, the HIGH alarm, or a sensor fault.
- MAINS:** Indicates that the unit is powered up and that the fuses are working.

3.1.3 Defrost & Alarm Set:

- DEFDUR:** The Defrost Duration. This is the duration of the defrost cycle in minutes. The period of duration can be set from 0 to 98 minutes.
- DWL:** Defrost Dwell Timer. This feature allows a "Dwell period" to be programmed from 0 to 20 min., for drain off (0 = no dwell).
- NOTE:** The dwell period will be overridden if a manual defrost is used (i.e. no dwell).
- SWCH:** This is a time delay to prevent the compressor from short-cycling. Each **DELAY** time the compressor is switched on, the timer is triggered. The compressor will subsequently not be allowed to switch on until the delay has expired.
- ALDELAY:** Alarm Delay (0 to 50 mins). After the maximum or minimum threshold temperature has been exceeded (AL-HI / AL-LO), the alarm will not be triggered until this time delay has expired. There are separate programmable AL DELAY periods for the High and Low alarm options
- ALOPTS:** Alarm Options. There are three alarm options available on the RCX 100.
- 1 - No flashing of LED's.
 - 2 - Flashing only when cold-room temperature is outside the Alarm maximum or minimum limits.
 - 3 - Flashing continues until maximum or minimum temperature is read.
- DEFREQ:** The Defrost Frequency. This is the duration of the refrigeration cycle in hours and can be set from 0 to 24 hours (0 = No defrost). Example, if the Defrost Frequency is set to 3 hours, this means that you will have 8 defrost cycles in every 24 hours.

3.2 PROGRAMMING THE RCX 100

3.2.1 Displaying the Room Temperature

When the unit is switched on, it goes through an initialisation routine which lasts about 3 seconds and ends with two beeps. The default display select is the cold room temperature. Pressing the **S** selector key will advance the display selector lamp to the next option. To advance quickly, hold the **S** key for an auto-repeat facility.

Note: If the display selector is left in any position other than the ROOM temperature for longer than one minute, it will automatically revert to showing the ROOM temperature.

3.2.2 Displaying the Evaporator Temperature

To view the evaporator temperature press the **S** key until the EVAP selector lamp is illuminated.

3.2.3 Setting the Room Temperature.

Press the **S** key until the ROOM SET selector lamp is illuminated, then press the **+** or **-** keys to set the required cold room temperature (minimum -40°C , maximum $+40^{\circ}\text{C}$).

3.2.4 Setting the Defrost Termination Temperature

Press the **S** key until the DEF TERM selector lamp is illuminated, then press the **+** or **-** keys to set the required defrost termination temperature (minimum -40°C , maximum $+50^{\circ}\text{C}$).

3.2.5 Setting the Fan Enable Temperature (Fan Delay)

Press the **S** key until the FAN ENABLE selector lamp is illuminated, then press the **+** or **-** keys to set the required fan enable temperature (minimum -40°C , maximum $+50^{\circ}\text{C}$).

3.2.6 Setting the Alarm Low Temperature Limit

Press the **S** key until the AL-LO selector lamp is illuminated, then press the **+** or **-** keys to set the alarm low limit (minimum -49°C , maximum $+49^{\circ}\text{C}$).

3.2.7 Setting the Alarm High Temperature Limit





Press the **S** key until the AL-HI selector lamp is illuminated, then press the **+** or **-** keys to set the alarm high limit (minimum -49°C , maximum $+49^{\circ}\text{C}$).



3.2.8 Setting the Defrost Duration

Press the **S** key until the DEF TERM selector lamp is illuminated. Then press the **D** key to select the DEF DUR option (this lamp will illuminate).

The defrost duration may now be set in minutes by pressing the **+** or **-** keys (0 to 98 min.).





3.2.9 Setting the Dwell period

Press the  key until the DEF TERM selector lamp is illuminated. Then press the  key to select the DWL option (this lamp will illuminate). If the Defrost Duration (DEF DUR) has not been set prior to this the DEF DUR lamp will illuminate, and in order to select the DWL option you must press the  key again until the DEF TERM selector lamp is illuminated and then press the  key to select the DWL option (this lamp will now illuminate).



The dwell period may now be set in minutes by pressing the  or  keys (0 to 20 min.).



NOTE: The dwell period will be overridden if a manual defrost is used (i.e. no dwell).

3.2.10 Setting the Compressor Switch Delay

Press the  key until the FAN ENABLE selector lamp is illuminated. Then press the  key to select the SWCH DELAY option (this lamp will illuminate). The compressor switching delay may now be set in minutes by pressing the  or  keys (0 to 10 mins).



3.2.11 Setting the Alarm Delay period

Press the  key until either the AL-LO or AL-HI selector lamp is illuminated (a different delay period can be set for the high and low alarms). Then press the  key to select the AL DELAY option (this lamp will illuminate).

The alarm delay period may now be set in minutes by pressing the  or  keys (0 to 50 min.).

3.2.12 Setting the Alarm Options

Press the  key until the AL-LO or AL-HI selector lamp is illuminated.

Then press the  key to select the AL OPTS option (this lamp will illuminate). The alarm mode options may now be set in minutes by pressing the  or  keys (1 to 3). Perform this operation for AL-LO and AL-HI. When the cold room temperature exceeds the AL-HI or AL-LO temperatures the corresponding lamp will flash after the temperature falls back within the permitted range, until the maximum (for AL-HI) or minimum (for AL-LO) temperature is read (see section 3.3.1 “maximum and minimum record temperatures”). This is optional and may be disabled, the modes are as follows:

- 1 - No flashing at all.
- 2 - Flashing only when the cold room temperature is outside the limits.
- 3 - Flashing continues until the maximum or minimum temperature is read.

3.2.13 Setting the Defrost Frequency

Press the **S** key until the DEF TERM selector lamp is illuminated. Then press the **F** key to select the DEF FREQ option (this lamp will illuminate).

The defrost frequency may now be set in hours by pressing the **+** or **-** keys (0 to 24 hrs). If you choose a setting of 3, this means you will have 8 defrost cycles in 24 hours.

3.2.14 Setting the Differential(Hysteresis)

The cold room thermostat has a variable differential of 0°C to 10°C. To view the existing differential, press the **S** key until the ROOM SET indicator is on. Now press the **D** key and the differential will be displayed. To adjust the differential, press the **+** or **-** key as appropriate, while holding the **D** key.

3.3 ADDITIONAL FEATURES

3.3.1 Maximum and Minimum Record Temperatures

To view the peak or maximum cold room temperature, ensure that the ROOM selector lamp is selected, and press the **+** key and hold in for 2 seconds. The bleeper sounds, and the display shows the maximum temperature reached since the unit was powered up. This may be reset to the present cold room temperature by pressing the **S** key whilst viewing the maximum recorded temperature. To view the maximum ever recorded temperature, continue to press the **+** key for a further eight seconds after the maximum temperature has been read (an "F" indicates that a sensor fault has occurred in the unit's history). The minimum temperature is viewed in a similar manner by pressing the **-** key. To view the maximum or minimum temperature for the Evaporator, ensure that the EVAP selector lamp is selected, then press and hold the **+** or **-** key to read the maximum or minimum recorded temperature respectively as above.

3.3.2 Keypad Lock

It is possible to lock the keypad so that the set values may not be accidentally changed.

To lock the keypad, press and hold the **S** key for eight seconds. The bleeper will then sound and a decimal point will appear to right of the display, showing that the present settings are fixed and protected. To unlock the keypad, press the **S** key for eight seconds and the decimal point will disappear.

3.3.3 Manual Defrost

To force the controller into a defrost cycle manually, or out of a defrost cycle, follow the steps below:

- 1 - Select the ROOM temperature for display.
- 2 - Press and hold the **D** key for five seconds.
- 3 - The unit will bleep, and change state.

3.3.4 Sensor Calibration Trimming.

The RCX 100 offers the facility for qualified personnel to adjust the calibration by $\pm 3^{\circ}\text{C}$ in 1°C steps. A known reference temperature should be used.

- 1 - Press the **S** key to select the temperature channel which requires calibration trimming (ROOM or EVAP).
- 2 - To increase the temperature reading by 1°C , press and hold the **+** and **F** keys together for five seconds. The unit will bleep and the temperature will change.

To decrease the temperature reading by -1°C , press and hold the **-** and **F** keys together for five seconds. The unit will bleep and the temperature will change.

3.3.5 Alarm Mute

To mute the alarm, press the **S** key to select AL-HI or AL-LO. The alarm will remain triggered, but will cease to sound.

3.3.6 Alarm Reset

To reset the alarm, adjust the temperature which has been exceeded, beyond the current room temperature (AL-HI or AL-LO).

3.3.7 Sensor Fault

In the case of a sensor fault, the sensor indicator will flash, the alarm will be triggered, the compressor and fan will stay on, and the defrost will be inhibited (i.e. the unit will not enter a defrost cycle).

SECTION 4- FAULT FINDING

- Problem:** Nothing happens when the unit is powered-up.
Cause / Remedy: One of the fuses could be blown - check and replace if necessary (refer to specifications for values). If the fuse blows again, contact the agent where the unit was purchased.
- Problem:** The temperature display is fluctuating.
Cause / Remedy: One of the sensor connections may be loose, Tighten connections and re-route cables if necessary.
- Problem:** Unable to set any of the parameters: Keypad will not operate.
Cause / Remedy: The keypad Lock is on - see 'Keypad Lock' section 3.3.2.
- Problem:** The AL-LO or AL-HI indicator is flashing.
Cause / Remedy: This is not a fault. The ROOM temperature is or has been either higher than the AL- HI set point, or lower than the AL-LO set point.
- Problem:** SENSOR indicator is flashing.
Cause / Remedy: One of the sensors is either faulty or not properly connected. The sensor which is causing the problem will show "F" on the display when selected. Check that all connections/couplers are secure. If the fault persists, replace the sensor.
- Problem:** The unit will not stay in a defrost cycle, whether automatically or by manual override.
Cause / Remedy: The defrost termination temperature has been exceeded (the evaporator temperature is higher than the defrost termination temperature). Adjust this pre-set to suit (see section 3.2.4).
- Problem:** Compressor will not operate.
Cause / Remedy: Check the Compressor Switch Delay (see section 3.2.10) and Thermostat Differential -Hysteresis (see section 3.2.14).
- Problem:** Fan will not operate.
Cause / Remedy: Check the Fan Enable Temperature (see section 3.2.5).
- Problem:** The unit is in an idle state, and none of the output indicators are active.
Cause/Remedy: The system is in a Dwell cycle (see section 3.2.9).

SECTION 5 - SPECIFICATIONS

ELECTRICAL:

Supply Voltage:	220-240 AC Single Phase
Ambient Temperature:	0°C to 40°C
Fuses:	2 x 1 A 20mm Quick Blow
Relay Outputs:	Compressor Relay: 13A single pole - (Resistive load) 735W Inductive load Fan Relay: 10A single pole - (Resistive load) 500W Inductive load Defrost Heater: 13A single pole -output live when energised (max 3KW) Alarm: 5A changeover 3 pin isolated (volt-free contacts - May be used for low or mains voltage)

MECHANICAL:

Dimensions :	RCX 100 Unit: width: 165mm height: 160mm depth: 75mm Sensor: diameter: 7.3mm (8.5mm for heat shrink)
Weight:	RCX 100 Unit: 0.96Kg
Box Material:	Plastic

SENSORS:

Type:	SX™ PT 100 Platinum Film
Compensation:	3 wire compensated
Cable Length :	Room sensor: 5m Evaporator sensor: 5m

PARTS LIST

RCX 100 Unit (with sensors)	C0318
RCX 100 Unit (no sensors)	C0406
Sensor (5m Cable)	A6905
Sensor (15m cable)	A6915
Sensor (25m Cable)	A6925
Sensor Extender 10m	A6911
Sensor Extender 20m	A6921
Sensor Extender 50m	A6951

CE

This product has been tested to the EU EMC 89/336/EEC directive according to the Manufacturers report, which is available upon request.

This product is in conformance with the Low Voltage Directive 73/23/EEC.

Thermomax certifies that this datalogging and / or control device has been manufactured to an ISO 9002 Quality System.

Thermomax undertakes to repair or replace the device if same is shown to be defective in its manufacture and / or components, but Thermomax shall not be responsible for any other financial or economic loss (or any indirect loss) which may be incurred by the buyer / customer or others in the use of the device.

Any claim for repair or replacement must be made not later than 15 months after the date of manufacture.

It is essential that a separate alarm / safety system is used in conjunction with this controller thereby safeguarding against any unanticipated failure.

SECTION 6 NEW FEATURES OF RCX 100 PANELMOUNT

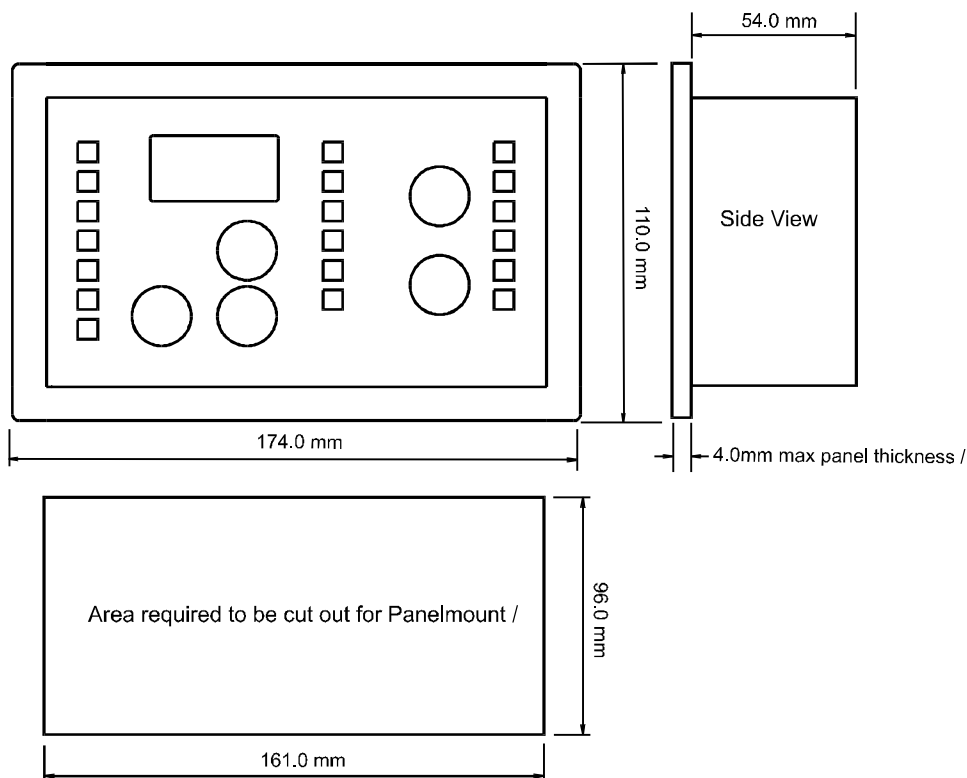

PANELMOUNT WIRING DIAGRAM

NOTE:
 RCX100 applications:
 CH1 = ROOM
 CH2 = EVAP

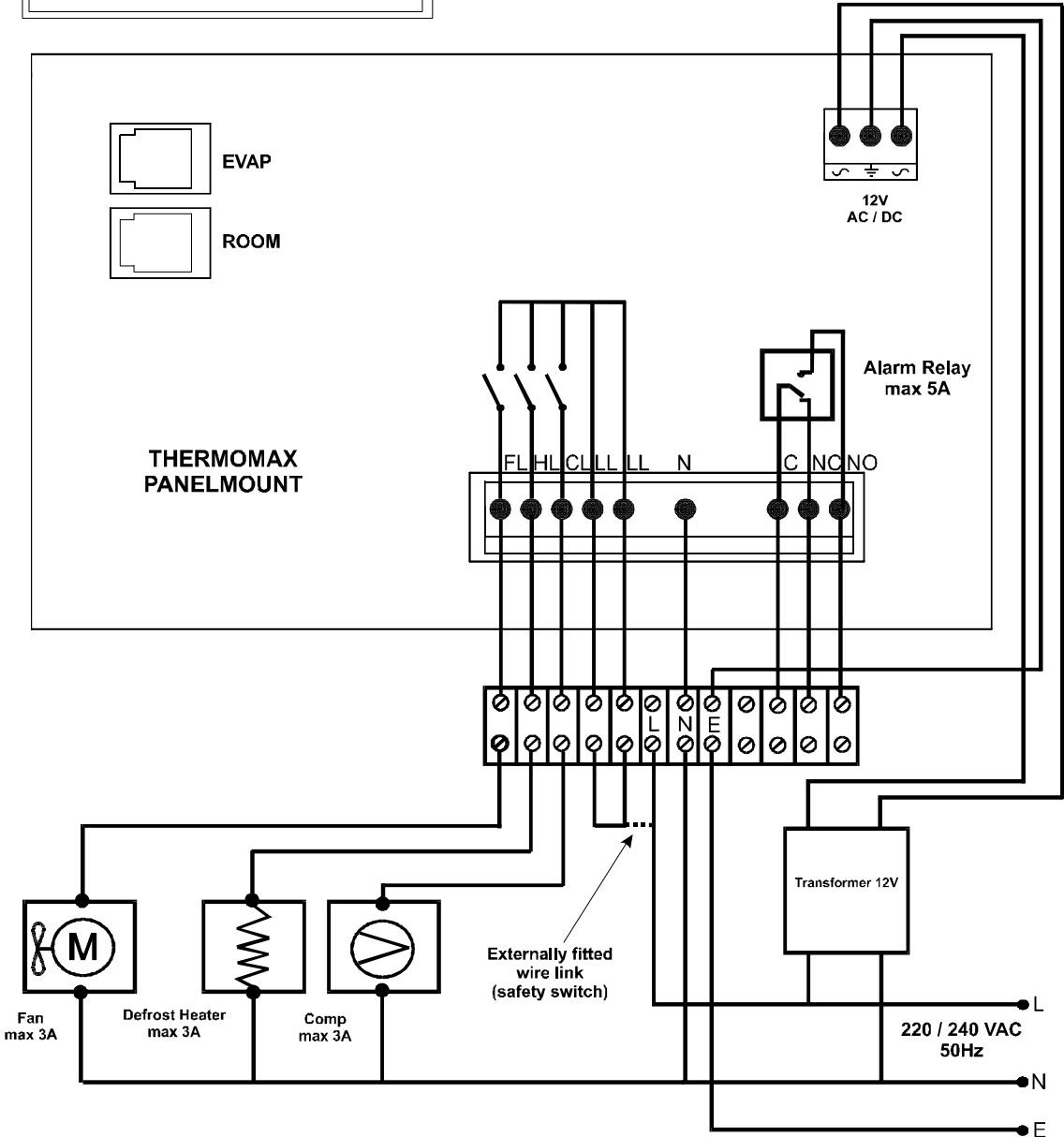

NOTE: The RCX 100 relay outputs should only be used to drive external contactors. They should not be connected directly to the Fan, Heater or Compressor.

SECTION 7 WIRING DIAGRAMS

RCX 100 MINI-PANEL WIRING DIAGRAM

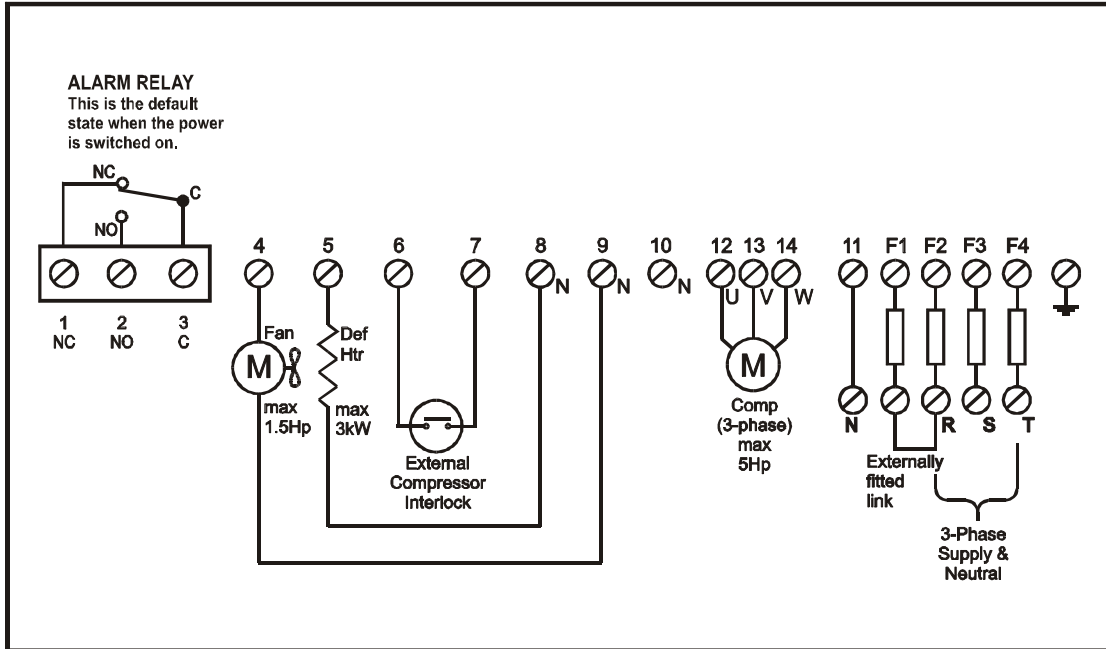

RCX 100 EASYFIX WIRING DIAGRAM

